

Fallguy *ULTRA 2*

UNIVERSAL EMBEDDED MP3 MODULE WITH SD-CARD SLOT AND 2 SERIAL HIGH-SPEED-INTERFACES



Hardware Version Rev.E 01/2022
Revised version – June 21st, 2023

Copyright 2004 – 2023, LOETRONIC ®
All rights reserved
www.loetronic.com
info@loetronic.com

Table of contents:

1. Overview	3
2. Technical data	3
3. Connection possibilities	4
4. Mechanical dimensions	7
5. Getting started	8
6. Firmware updates with the integrated bootloader	8

This data sheet and the product described herein were designed carefully by the manufacturer. We have made every effort to avoid mistakes but we cannot guarantee that it is 100% free of errors. The manufacturer's entire liability and your exclusive remedy shall be, at the manufacturer's option, return of the price paid or repair or replacement of the product. The manufacturer disclaims all other warranties, either expressed or implied, including but not limited to implied warranties of merchantability and fitness for a particular purpose, with respect to the product including accompanying written material, hardware, and firmware. In no event shall the manufacturer or its supplier be liable for any damages whatsoever (including, without limitation, damages for loss of business profits, business interruption, loss of business information, or other pecuniary loss) arising out of the use of or inability to use the product, even if the manufacturer has been advised of the possibility of such damages. The product is not designed, intended or authorized for use in applications in which the failure of the product could create a situation where personal injury or death may occur. Should you use the product for any such unintended or unauthorized application, you shall indemnify and hold the manufacturer and its suppliers harmless against all claims, even if such claim alleges that the manufacturer was negligent regarding the design or implementation of the product.

Product features and prices may change without notice.

All trademarks are property of their respective holders.

1. Overview

The Fallguy ULTRA 2 MP3 module (Article No.0186) is an universal and compact embedded module for playing and recording audio data (MP3, Ogg Vorbis, AAC, WMA, FLAC, WAV, MIDI). The module was designed for use in embedded systems and for integration in customer specific environment. It is a versatile audio module for working in rough industrial applications.

The module has a SD-card slot for using with SD cards type SD or SDHC.

Controlling the module can be done either by buttons, digital and analog inputs or via the different serial interfaces. A connection for additional electronic to connect to a RS232-, RS485-, LAN- (XPORT) or USB-interface (FTDI-IC) as well as to a LC-display is provided

Depending on the customer's requirements, the internal firmware of the module can be adapted to the application-specific requirements. The playback behaviour of the module is determined by the firmware used.

Optional adapter PCBs with RS232-, RS485-, LAN- and USB-interface, as well as connections for buttons, a LC-display and amplifiers for loudspeaker and headphones are available (Fallguy ULTRA Carrier Boards by LOETRONIC, see www.loetronic.com).

2. Technical data

Microcontroller:

- 16-Bit microcontroller PIC24FJ256GL408
- 256 kByte flash memory for the internal firmware
- 32 kByte RAM
- Internal EEPROM for storing configuration data

MP3-En/Decoder:

- Hardwaredecoder (DSP) VS1063
- Decodes MPEG1 Layer III (MP3), MPEG2 and MPEG2.5 Layer III with up to 320 kbit/s or variable bitrate, Ogg Vorbis, AAC WMA, FLAC, MIDI
- Encodes MPEG1 Layer III (MP3), Ogg Vorbis, WAV
- Volume and equalizer control
- Integrated A/D- and D/A-Converter

Flash-memory:

- SD-cards from 64 MB to 128 GB usable (SD and SDHC)
- FAT32 file format
- Playback length (example) with 4 GB memory and 128 kbit/s MP3 encoding about 72 hours

Operating temperature:

- -20 °C to +85 °C

Operating voltage:

- 3.3 V (DC) stabilized

Current consumption:

- 100 mA (typical) with SD card

Interfaces:

- 8 button or analog inputs for connecting buttons, sensors or relays
- 8 digital in- or outputs
- 1 asynchronous serial interface (UART, 3.3V level, 115.200 bps) for RS232- or RS485 connections with hardware handshake
- 1 asynchronous serial interface (UART, 3.3V level, 921.600 bps) for LAN- (XPORT) or USB-interfaces (FTDI-IC) with hardware handshake
- 1 interface for an LC-display (4-bit)
- 5 connections for additional LEDs
- 1 interface for an additional RTC module
- 1 interface for an additional RF receiver
- 1 analog audio output – Line level
- 1 digital audio output – I2S, 48kHz
- 1 analog audio input – Line level

3. Connection possibilities

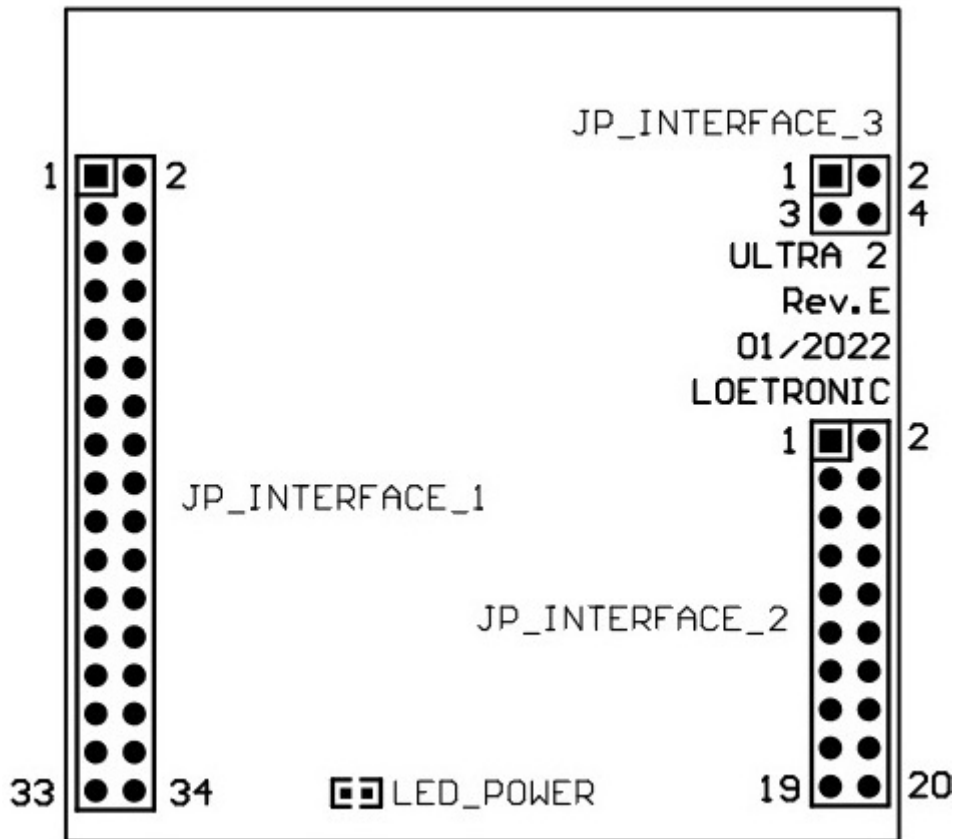

Picture 3.1 Fallguy ULTRA 2 MP3 module Rev.E – Connections

JP_INTERFACE_1

- The JP_INTERFACE_1 interface is for connecting the power supply, external periphery and the audio outputs. The internal firmware of the module must be programmed to use the in- and outputs from this interface. Every ULTRA 2 MP3 module is equipped with the standard firmware or a customer specific firmware and is delivered with a datasheet describing all functions of this interface.
- All in- and outputs have 0 – 3.3 Volt level, unless otherwise noted!**
- By using the sockets from the interface (2x17, RM2.54) the module can be attached simply to another PCB (for example a Fallguy ULTRA Carrier Board by LOETRONIC, see www.loetronic.com).
- Depending on the functions external PullUp oder PullDown logic must be added!
- All in- and outputs of the J_INTERFACE_1 interface are connected directly to the microcontroller on the module. If they are used, they must be protected by series resistors and the voltage level of 0 – 3.3 V must be maintained.
- Non conforming voltage levels can damage the microcontroller on the module!**

Assignment:

Pin-No.	Name	Description
1	LINE_OUT_L	Analog audio output left (Line level)
2	LINE_OUT_R	Analog audio output right (Line level)
3	3.3V	3.3 Volt external power supply for the module (DC, stabilized)
4	GND	Ground potential for the module
5	SCLK	Digital audio output I2S – SCLK
6	SDATA	Digital audio output I2S – SDATA
7	MCLK	Digital audio output I2S – MCLK
8	LRCK	Digital audio output I2S – LRCK
9	XPORT_CP3 / CTS	Digital handshake line for XPORT (LAN) or FTDI-IC (USB)
10	XPORT_CP1 / RTS	Digital handshake line for XPORT (LAN) or FTDI-IC (USB)
11	XPORT_RST	Reset line for XPORT (LAN) or FTDI-IC (USB)
12	SERIAL_RTS	Digital handshake line for UART(RS232-function: RTS, RS485-function: RE)
13	SERIAL_CTS	Digital handshake line for UART(RS232-function: CTS, RS485-function: TE)
14	AMP_STBY	Control line for Fallguy ULTRA AMP Carrier Board
15	AMP_MUTE	Control line for Fallguy ULTRA AMP Carrier Board
16	GPIO_1	Digital in- or output
17	GPIO_2	Digital in- or output
18	GPIO_3	Digital in- or output
19	GPIO_4	Digital in- or output
20	GPIO_5	Digital in- or output
21	GPIO_6	Digital in- or output
22	GPIO_7	Digital in- or output
23	GPIO_8	Digital in- or output
24	RTC_SCL	Control line for RTC module
25	RTC_SDA	Control line for RTC module
26	LCD_RS	Control line for LC-display – RS
27	LCD_E	Control line for LC-display – E
28	LCD_DB4	Data line for LC-display – DB4
29	LCD_DB5	Data line for LC-display – DB5
30	LCD_DB6	Data line for LC-display – DB6
31	LCD_DB7	Data line for LC-display – DB7
32	PGEC	Internal programming line
33	PGED	Internal programming line
34	MCLR	Internal reset line (Activ low)

JP_INTERFACE_2

- The JP_INTERFACE_2 interface is for connecting external periphery. The internal firmware of the module must be programmed to use the in- and outputs from this interface. Every ULTRA 2 MP3 module is equipped with the standard firmware or a customer specific firmware and is delivered with a datasheet describing all functions of this interface.
- All in- and outputs have 0 – 3.3 Volt level, unless otherwise noted!**
- By using the sockets from the interface (2x10, RM2.54) the module can be attached simply to another PCB (for example a Fallguy ULTRA Carrier Board by LOETRONIC, see www.loetronic.com).
- Depending on the functions external PullUp oder PullDown logic must be added!
- All in- and outputs of the J_INTERFACE_2 interface are connected directly to the microcontroller on the module. If they are used, they must be protected by series resistors and the voltage level of 0 – 3.3 V must be maintained.
- Using the serial interfaces (1. and 2. UART) the ULTRA 2 MP3 module can be controlled externally by a PC or microcontroller. The voltage level is 0 – 3.3 Volt for both interfaces. An ASCII-based protocol is an element of the standard firmware and is the same for both interfaces. The 1. UART is for use with an RS232- or RS485-connection, the 2. UART is for use with a LAN- (XPORT) or USB-interface (FTDI-IC). The necessary electronic (Level converter, XPORT or FTDI-IC) must be provided externally or are provided using a Fallguy ULTRA Carrier Board. More adjustments of the serial interfaces are defined through the selected firmware and are not described in this datasheet. Every ULTRA 2 MP3 module is equipped with the standard firmware or a customer specific firmware and is delivered with a datasheet describing all functions of the serial interface.
- Non conforming voltage levels can damage the microcontroller on the module!**

Assignment:

Pin-No.	Name	Description
1	XPORT_DIN / RXD	Digital send line for the 2. serial UART (module->) – 921.600bps
2	XPORT_DOUT / TXD	Digital receive line for the 2. serial UART (module<-) – 921.600bps
3	SERIAL_TX	Digital send line for the 1. serial UART (module->) – 115.200bps
4	SERIAL_RX	Digital receive line for the 1. serial UART (module<-) – 115.200bps
5	BUTTON_8	Button- or analog input
6	BUTTON_7	Button- or analog input
7	BUTTON_6	Button- or analog input
8	BUTTON_5	Button- or analog input
9	BUTTON_4	Button- or analog input
10	BUTTON_3	Button- or analog input (Config LAN/XPORT function)
11	BUTTON_2	Button- or analog input (Config LAN/XPORT function)
12	BUTTON_1	Button- or analog input (Bootloader function)
13	LED_EXT5	Digital output for external LED 5
14	LED_EXT4 / RF_REQ	Digital output for external LED 4 or control line for RF receiver
15	LED_EXT3 / RF_SDA	Digital output for external LED 3 or control line for RF receiver
16	LED_EXT2 / RF_SCL	Digital output for external LED 2 or control line for RF receiver
17	LED_EXT1 / RF_RST	Digital output for external LED 1 or control line for RF receiver
18	LED_NET	Digital output for network-LED (Serial interface or LAN activity)
19	LED_SD	Digital output for SD-LED (SD-card activity)
20	LED_BLD	Digital output for Bootloader-LED (Bootloader function)

JP_INTERFACE_3

- The JP_INTERFACE_3 interface is for connecting the audio inputs.
- By using the sockets from the interface (2x2, RM2.54) the module can be attached simply to another PCB (for example a Fallguy ULTRA Carrier Board by LOETRONIC, see www.loetronic.com).

Assignment:

Pin-No.	Name	Description
1	LINE_IN_L	Analog audio input left (Line level)
2	LINE_IN_R	Analog audio input right (Line level)
3	AGND	Ground potential for the audio inputs
4	AGND	Ground potential for the audio inputs

LED_POWER

- The led LED_POWER on the ULTRA 2 MP3 module lights up, if the module is supplied with a voltage of 3.3 Volt.

4. Mechanical dimensions

Dimensions:

- Length: 55 mm / 2.17 inch, Width: 55 mm / 2.17 inch, Height: 16.5 mm / 0.65 inch

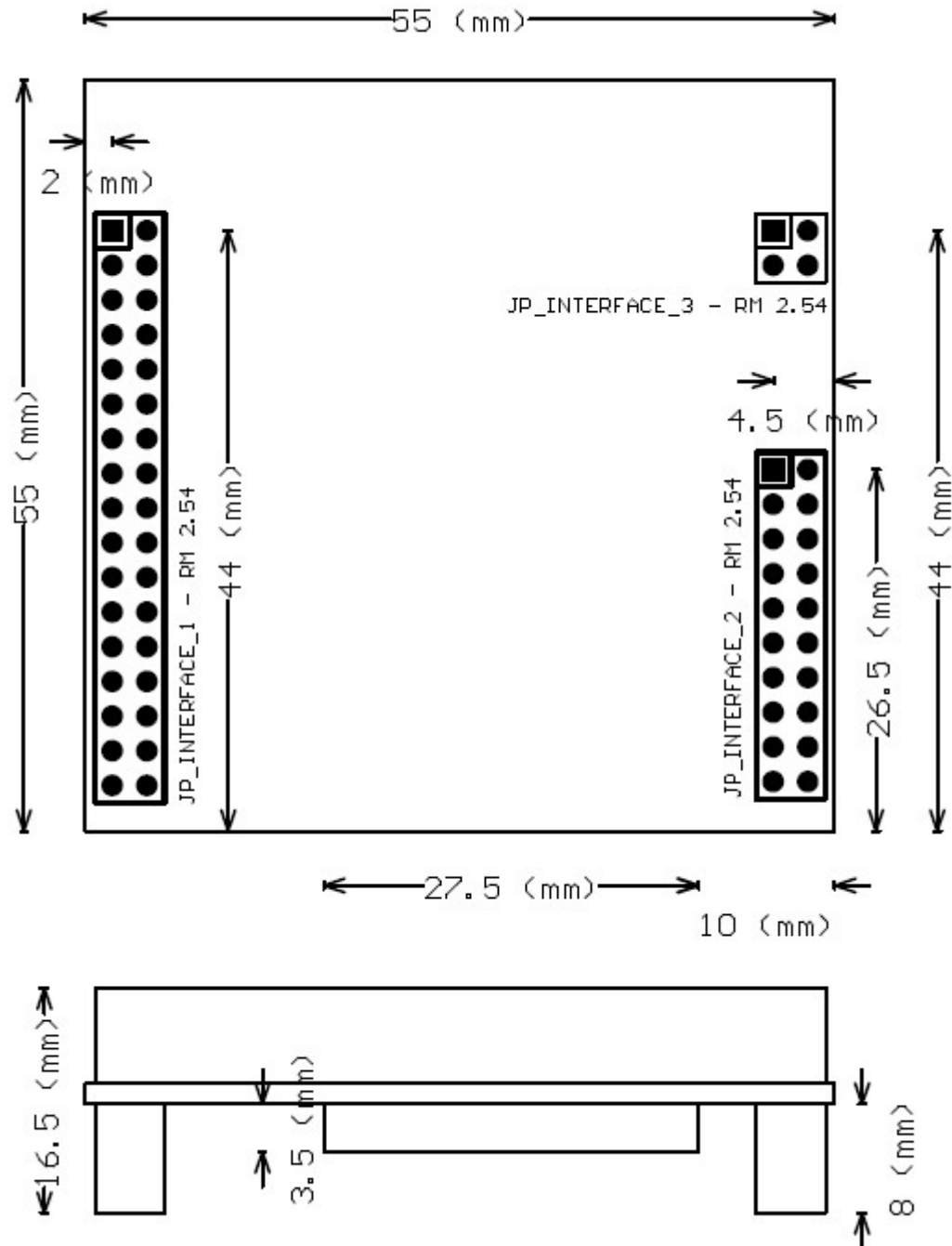

Picture 4.1 Fallguy ULTRA 2 MP3 module Rev.E - Dimensions

5. Getting started

The Fallguy ULTRA 2 MP3 module must be connected with a voltage source of 3.3 Volt (DC) at Pin 3 and 4. An external amplifier can be connected at Pin 1, 2 (Line level) and at Pin 4 (Ground) of JP_INTERFACE_1. The audio source (Line level) can be connected to Pin 1, 2 and at Pin 3, 4 (Ground) of JP_INTERFACE_3. More electronic can be connected according its function to the different in- an outputs. LOETRONIC recommends to use a Fallguy ULTRA Carrier Board (see www.loetronic.com) to use all the different in- and outputs. The MP3 module has to be clipped simply on the Carrier Board. Exemplary circuits for the different interfaces can be found also in the datasheet for the Fallguy ULTRA Carrier Board.

If no Fallguy ULTRA Carrier Board and also no other additional electronic is used, at least PullUp-resistors (10k Ohm to 3.3 V) at the 8 button inputs (respectively BUTTON_1 – BUTTON_8) must be connected!

Any SD flashcard – type SD or SDHC - can be used. The SD card must be formatted in **FAT32** with standard settings and there must only be one partition on it.

The playback attitude is defined through the programmed firmware and is not described in this datasheet. Every ULTRA 2 MP3 module is equipped with the standard firmware or a customer specific firmware and is delivered with a datasheet describing all functions, settings and the ASCII protocol of this interface.

6. Firmware updates with the integrated bootloader

To program a new firmware file into the internal flash memory of the microcontroller, the firmware file (*.LOE) must be in the main directory of the SD card. There should be only one firmware file in the main directory!

Deleting and programming the internal flash memory is done by the internal bootloader of the ULTRA 2 MP3 module. When the module is off, the first button (**Button_1 / T1 / Play/Pause**) must be pressed (bridged with ground) and then it must be turned on with the button pressed down. The ULTRA 2 MP3 module will now boot up the bootloader and the Bootloader-LED (LED_BLD) will light up. The programming sequence is automatically initiated, this means the module reads the firmware file in the main directory (*.LOE), erases the memory and programs it with the new firmware. As it is ready, the module will boot up the new firmware and the Bootloader-LED will go off.

To display errors and to diagnose them, the Bootloader-LED is used. It will blink every 0,5 s up, if there was a problem initialising the SD card or programming the flash memory. The counts of blinking up represent the error and will repeated every 3 s.

Error messages ULTRA 2 BOOTLOADER V2.02:

- 1 – Sector cannot be erased -> Module is broken
- 3 – Sector cannot be programmed -> Module is broken
- 5 – Firmware file (*.LOE) on the SD card is corrupted
- 6 – Partition signature (FAT32) not found -> SD card has to be reformatted
- 8 – Partition table (FAT32) not ok -> SD card has to be reformatted
- 9 – Firmware file (*.LOE) not found in main directory of the SD card
- 11 – SD card is not available